

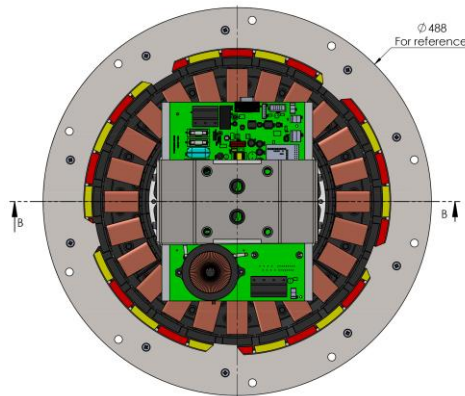

DESIGN, DEVELOPMENT, AND MANUFACTURING OF BRUSHLESS
PERMANENT MAGNET MOTORS, MOTOR CONTROL AND MOTOR DRIVES

3-Day Online Workshop on Motor, Inverter, Hardware, and Firmware Design Techniques for Permanent Magnet Brushless Motors – A System Approach

April 22, 23 and 24, 2025





DESIGN, DEVELOPMENT, AND MANUFACTURING OF BRUSHLESS
PERMANENT MAGNET MOTORS, MOTOR CONTROL AND MOTOR DRIVES

Table of Contents

Contents

Table of Contents	2
1.0 Introduction: The Journey of Passion, Perfection and Extraordinary Knowledge	4
2.0 Lessons from the Trenches	4
3.0 Course Objectives	5
4.0 Course Advantages	6
5.0 Who Should Attend	6
6.0 Day One: Fundamentals, Dynamic Modeling, Mechanical Aspects, and Simulations	7
7.0 Day Two: Inverter, Hardware, and Firmware Design and Detailed Design Examples. Hardware and Firmware Design, Modeling, and Simulation using ALTAIR EMBED™ and LTSpice™	7
8.0 Day Three: Finite Element Analysis, System Simulations, and Detailed Design Examples	8
9.0 Workshop Schedule	9
9.1 Day One: Fundamentals, Dynamic Modeling, Mechanical Aspects and Simulations	9
9.2 Day Two: Inverter, Hardware and Firmware Design and Detailed Design Examples. Hardware and Firmware Design, Modeling and Simulation using ALTAIR EMBED™ and LTSpice™.	12
9.3 Day Three: Finite Element Analysis, System Simulations, and Detailed Design Examples	14
10.0 About Us	18
Team at PEG	20
Motor engineers	20
Electrical engineers	20
Mechanical engineers	20
Software engineers	20
Embedded engineers	20
Layout engineers	20
Test engineers	21
Project engineers	21
Research & Simulation engineers	21
Manufacturing engineers	21



DESIGN, DEVELOPMENT, AND MANUFACTURING OF BRUSHLESS
PERMANENT MAGNET MOTORS, MOTOR CONTROL AND MOTOR DRIVES

11.0 Our Vision	21
12.0 Our Mission	21
13.0 Our Core Values	21
14.0 About Rakesh	22
16.0 Some of our customers	23
17.0 Registration Details	23
How to Register	24
18.0. Course Deliverables	24
19.0. Cancellation Policy	24
Contact Information	24



DESIGN, DEVELOPMENT, AND MANUFACTURING OF BRUSHLESS
PERMANENT MAGNET MOTORS, MOTOR CONTROL AND MOTOR DRIVES

1.0 Introduction: The Journey of Passion, Perfection and Extraordinary Knowledge

A groundbreaking idea is born in moments, but engineering it into reality takes expertise, experience, and patience. This workshop distills decades of knowledge in motors, motor drives, and power electronics into a structured, practical learning experience. Power Electronics Group (PEG) has led innovation in the industry for years, and this workshop provides first-hand insights from our extensive experience.

“We are committed to empowering you with the knowledge and expertise we've gained over the years, making your journey smoother and your success more achievable.”

This workshop has been a culmination of our work in motors, motor drives, and power electronics for the last 34 years. Power Electronics Group (formerly Strategic Technology Group) has launched the most innovative and revolutionary products in motors and motor drives in the past fifteen years. So, we speak with the experience of having lived through each of these products from conception to manufacturing launch to continuous perfection. The mistakes were grand, the lessons were painful, the knowledge discovery was extraordinary, and the passion and dedication were without question. You required all to win at the end.

2.0 Lessons from the Trenches

We believe that a real-world-class product in motors and motor drives is impossible without in-depth knowledge of all aspects of the systems. Engineering world-class brushless motor systems requires mastery of four key domains:

1. Motor.
2. Inverter.
3. Hardware.
4. Firmware.

And it is not that hard to learn all aspects. The needs of the hour pushed us hard to help our team of engineers solve serious design problems. And the benefits of this learning to all were tremendous. This workshop provides an integrated approach to



DESIGN, DEVELOPMENT, AND MANUFACTURING OF BRUSHLESS
PERMANENT MAGNET MOTORS, MOTOR CONTROL AND MOTOR DRIVES

understanding these components, emphasizing practical applications and real-world problem-solving.

Engineering a world-class wonder is never easy, and it requires taking prudent risks and a profound discovery and application of knowledge. Experience and challenging lessons from the trenches are most valuable.

"For a Company, Cumulative Discovery of Knowledge and its Application must reach a Critical point for it to matter. The journey must be Passionate and Patient."

This Course brings comprehensive and practical knowledge together in a 3-day course on the motor, inverter, hardware, and firmware design techniques with a system approach. A system approach is critical because it forces engineers to evaluate problems with a 360-degree view rather than a narrow portion.

Only an in-depth knowledge of motor characteristics can help develop great hardware and firmware. Knowing the limitations of hardware and firmware helps us develop an excellent motor. No cost reduction is possible without optimizing each component for their best performance individually and at a system level.

3.0 Course Objectives

This Course aims to impart knowledge of techniques for developing brushless permanent magnet motors, drives, and systems. The Course has the following objectives:

1. Provide the participants with training techniques for simulating, designing, and analyzing brushless permanent magnet motor systems.
2. Allow the participants to evaluate various tools & strategies and understand practical constraints for different approaches.
3. Help the participants learn how to assess their brushless permanent magnet motor systems design procedures and determine when specific methods can be most effective.



DESIGN, DEVELOPMENT, AND MANUFACTURING OF BRUSHLESS
PERMANENT MAGNET MOTORS, MOTOR CONTROL AND MOTOR DRIVES

4. Provide the participants with tools and techniques for reevaluating their current brushless permanent magnet motor systems with new tools and methods.
5. Demonstrate these methods for various brushless permanent magnet motor systems.
6. Provide working circuits and models.

4.0 Course Advantages

1. Enhance and advance your knowledge of brushless permanent magnet motor systems.
2. Develop innovative brushless permanent magnet motor systems.
3. Enhance your team's skills dramatically in brushless permanent magnet motor systems.
4. Engage in more effective brushless permanent magnet motor system program management for your company.
5. Significantly cut development time.
6. Predict and eliminate failure rates.
7. Improve quality & reliability.
8. Innovate with new techniques.
9. Reduce cost.
10. Improve manufacturability.
11. Compare several alternative solutions.

5.0 Who Should Attend

1. Motor and Generator Engineers (Beginners and Advanced).
2. Drive and Control Engineers.
3. Embedded Systems Engineers.
4. Power Electronics Engineers.
5. Application Engineers.
6. Engineering Directors.
7. Engineering and R&D Managers.
8. Electrical Engineers.
9. System Engineers.



DESIGN, DEVELOPMENT, AND MANUFACTURING OF BRUSHLESS
PERMANENT MAGNET MOTORS, MOTOR CONTROL AND MOTOR DRIVES

10. Product Development Engineers.
11. Faculty and Students.

6.0 Day One: Fundamentals, Dynamic Modeling, Mechanical Aspects, and Simulations

- Introduction to BLDC and PMSM motors
- Motor Architecture and Analytical Design Methods
- Power transmission, motor selection, and thermal analysis
- Dynamic modeling and simulation with LTSpice™.

Day One of the Course will cover the dynamic modeling of BLDC motors, motor design considerations, motor architectures, analytical design methods, and introduction to space vectors. Mechanical aspects such as power transmission basics, motor selection criteria, motor mounting methods, mechanical failure modes, and thermal analysis will also be covered. Several LTSpice™ simulations covering dynamic modeling will be demonstrated.

7.0 Day Two: Inverter, Hardware, and Firmware Design and Detailed Design Examples. Hardware and Firmware Design, Modeling, and Simulation using ALTAIR EMBED™ and LTSpice™

- Power stage design and inverter control strategies
- Hardware and peripheral circuit design
- Processor selection and firmware development techniques
- Real-world design examples and simulation demonstrations

Day Two of the Course will focus on hardware and firmware design, power stage design, inverter and peripheral circuit design, and network for motor control systems.

Day two of the Course will also cover two designs (motor + controller) in detail, along with the design calculations, simulations, processor selection, circuit design, and final



DESIGN, DEVELOPMENT, AND MANUFACTURING OF BRUSHLESS
PERMANENT MAGNET MOTORS, MOTOR CONTROL AND MOTOR DRIVES

performance results. Also, ALTAIR EMBED™ be demonstrated as a tool for firmware development along with MATLAB and Simulink. BLDC motor and drive problems, solutions, and driving algorithms will be presented in detail.

8.0 Day Three: Finite Element Analysis, System Simulations, and Detailed Design Examples

- 2D Finite Element Analysis (FEA) using FEMM and MotorSolve™
- Motor control algorithms and space vector modulation
- Firmware development for sensor-less control
- Hands-on simulations and real-world case studies

Day Three of the Course will cover 2D finite elements analysis and simulations. Several motor designs will be considered based on design specifications. FEMM 2D Electromagnetic Field Simulation Software, MotorSolve™, and LTSpice™ analysis and simulations will be demonstrated.



DESIGN, DEVELOPMENT, AND MANUFACTURING OF BRUSHLESS
PERMANENT MAGNET MOTORS, MOTOR CONTROL AND MOTOR DRIVES

9.0 Workshop Schedule

9.1 Day One: Fundamentals, Dynamic Modeling, Mechanical Aspects and Simulations

Table 1: Day One Schedule

	Fundamentals, Dynamic Modeling, Mechanical Aspects and Simulations
	Day 1
9:30	The Fundamentals
10:30	Basic Design Considerations
11:00	Coffee Break
11:15	Motor and Magnetic Architectures
12:15	Analytical Methods
13:00	Lunch
14:00	An Introduction to Space Vectors
15:00	Power Transmission Basics
15:30	Coffee Break
15:45	Motor Selection Criteria
17:00	Motor Mounting Methods
17:30	End

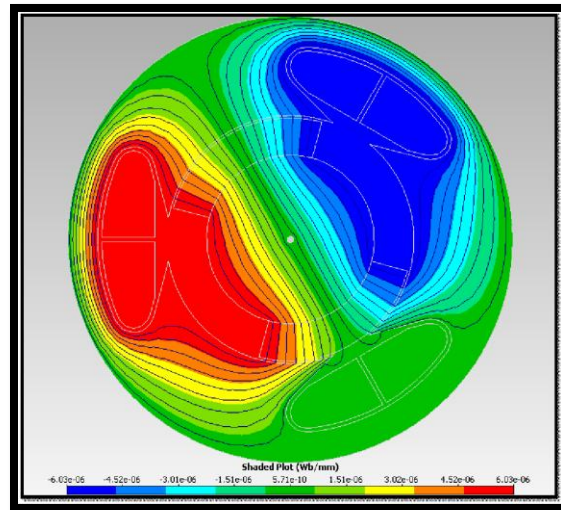

Figure 1: Use of FEA for Dynamic Modeling of PMSM: FEA can be used to estimate the L_d and L_q parameters and saliency of the machine, and consequently, these parameters can be used to simulate the complete system behavior and performance in LTSpice or Simulink.



DESIGN, DEVELOPMENT, AND MANUFACTURING OF BRUSHLESS PERMANENT MAGNET MOTORS, MOTOR CONTROL AND MOTOR DRIVES

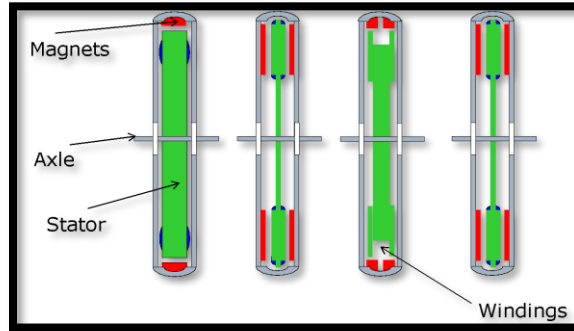

Figure 2: Motor Architectures: Day one will discuss various motor architectures. An example of external rotor motor architecture is shown in Figure 2.

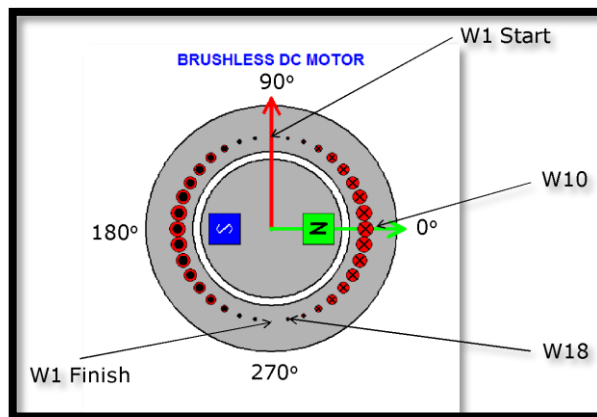

Figure 3: Understanding Space Vector Fundamentals: Day one will discuss space vector fundamentals and how the winding currents help generate the space vector fundamentals. Understanding the space vectors is critical in designing and optimizing motors and drives.

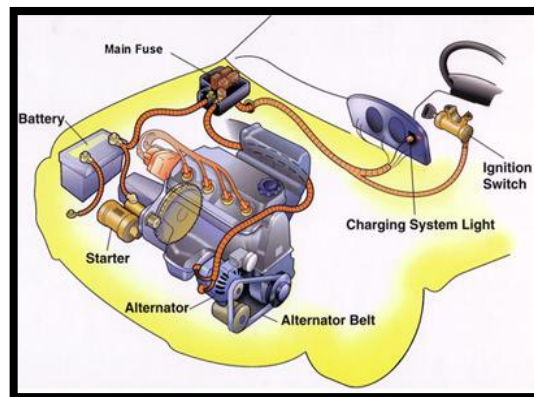

Figure 4: Starter Alternator Design Considerations



DESIGN, DEVELOPMENT, AND MANUFACTURING OF BRUSHLESS PERMANENT MAGNET MOTORS, MOTOR CONTROL AND MOTOR DRIVES

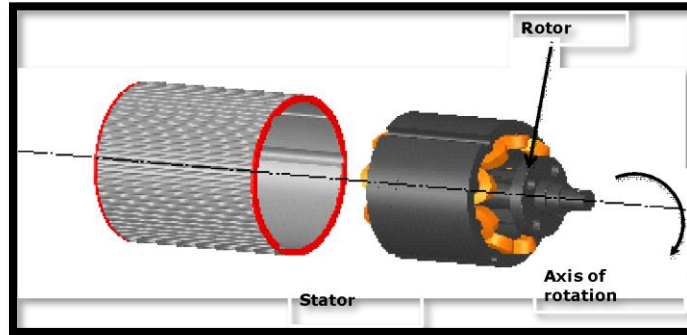

Figure 5: Mounting Considerations for Brushless PMSM

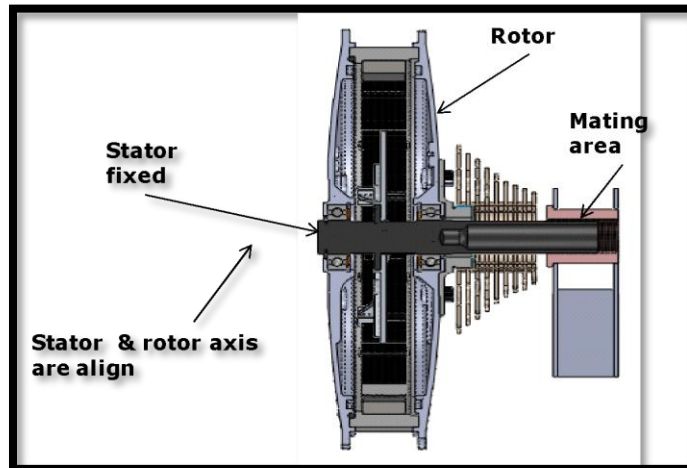

Figure 6: Illustration of Principles of Mounting

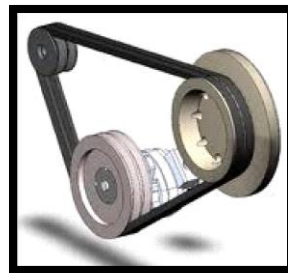

Figure 7: Power Transmission Basics

DESIGN, DEVELOPMENT, AND MANUFACTURING OF BRUSHLESS PERMANENT MAGNET MOTORS, MOTOR CONTROL AND MOTOR DRIVES

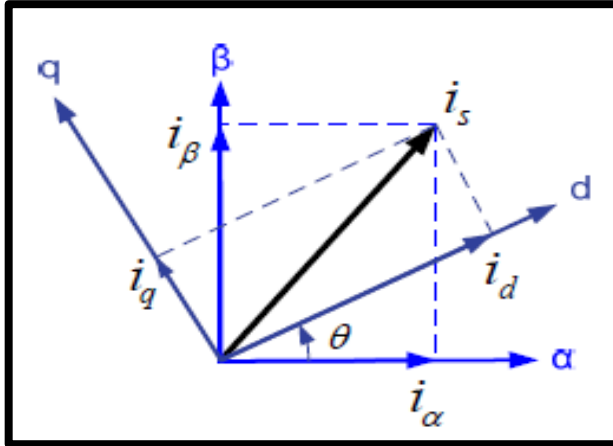

Figure 9: Transformations from Rotary Axis to Stationary Axis and Vice Versa

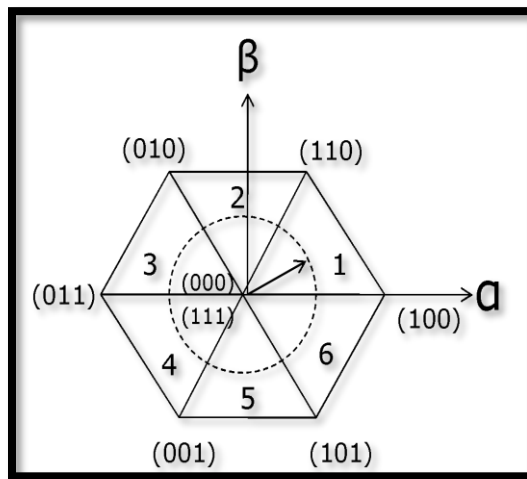

Figure 10: Deriving the Space Vector Model



DESIGN, DEVELOPMENT, AND MANUFACTURING OF BRUSHLESS
PERMANENT MAGNET MOTORS, MOTOR CONTROL AND MOTOR DRIVES

9.3 Day Three: Finite Element Analysis, System Simulations, and Detailed Design Examples

Table 3: Day 3 Schedule

Finite Element Analysis, System Simulations and Detailed Design Examples	
Day 3	
9:30	Driving Algorithms
10:30	Driving Algorithms
11:00	Coffee Break
11:15	Driving Algorithms
12:15	Designing from Specifications
13:00	Lunch
14:00	Finite Element Analysis
15:00	Finite Element Analysis
15:30	Coffee Break
15:45	Simulations
17:00	Simulations
17:30	End

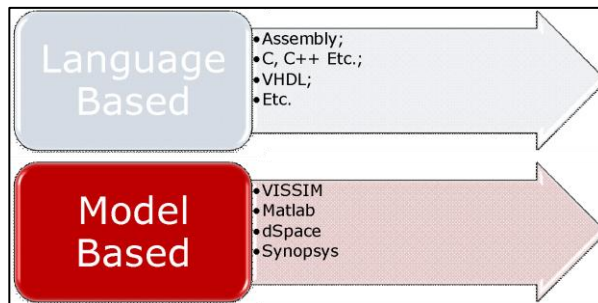

Figure 11: With Model-based tools such as ALTAIR EMBED™, code development and maintenance are significantly simplified.

DESIGN, DEVELOPMENT, AND MANUFACTURING OF BRUSHLESS PERMANENT MAGNET MOTORS, MOTOR CONTROL AND MOTOR DRIVES

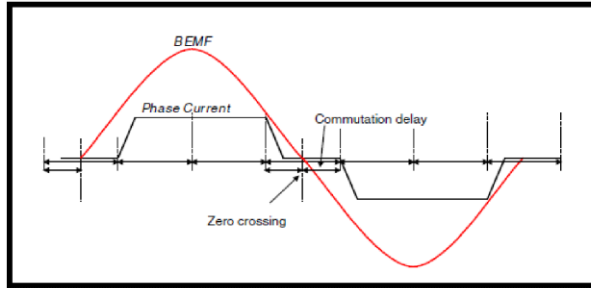

Figure 12: Using an 8-bit microcontroller for sensor-less control

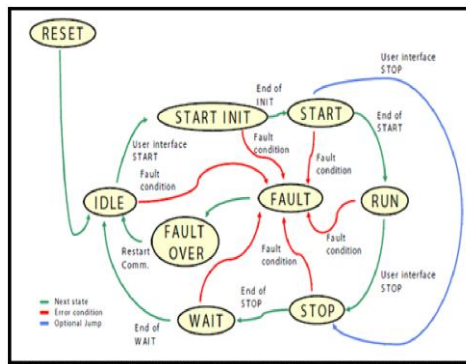

Figure 13: State Machine for Firmware Implementation and Execution

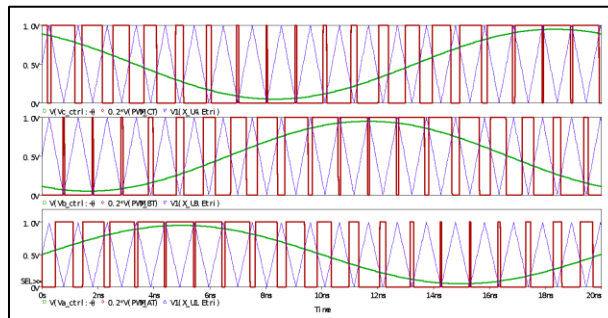

Figure 14: Sinusoidal Control Methods for Controlling PMSM

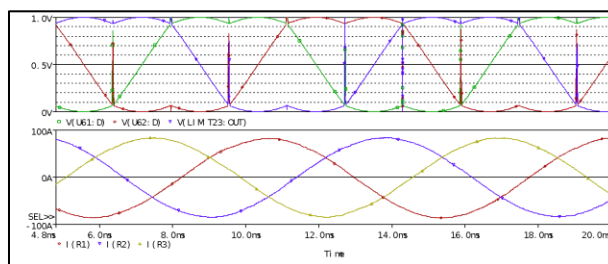

Figure 15: Space Vector Simulation and Implementation

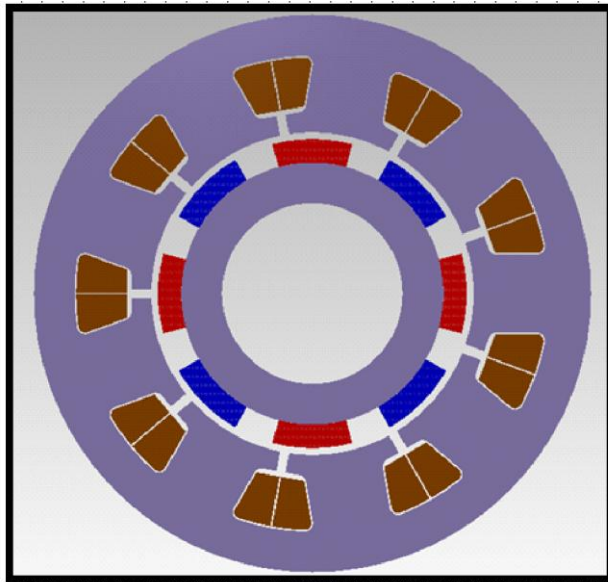

Figure 16: Finite Element Analysis using MotorSolve™

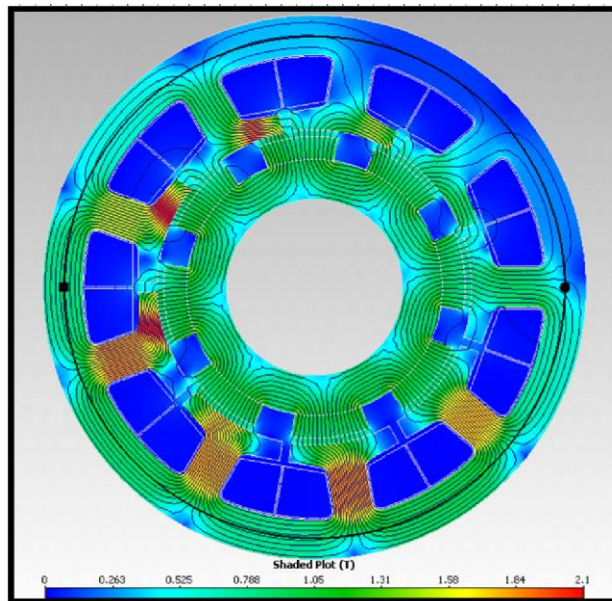

Figure 17: Flux and Flux Density Distribution

DESIGN, DEVELOPMENT, AND MANUFACTURING OF BRUSHLESS
PERMANENT MAGNET MOTORS, MOTOR CONTROL AND MOTOR DRIVES

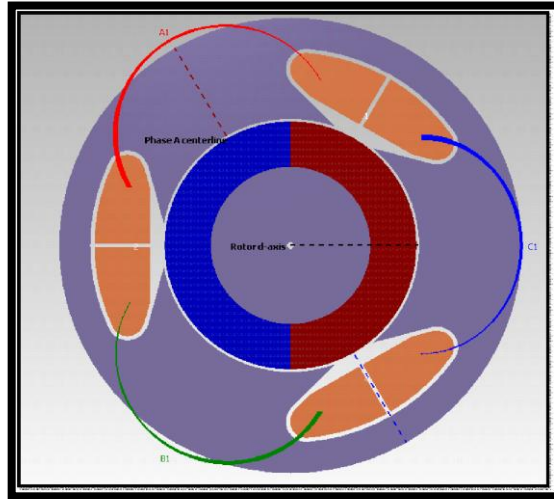

Figure 18: Understanding Winding Arrangements and Space Vectors

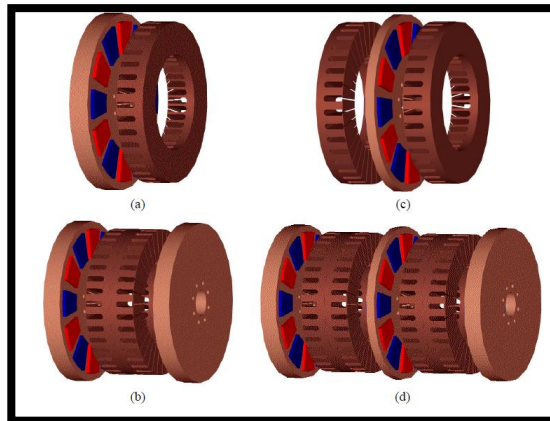

Figure 19: 3D Finite Element Analysis using MagNet™ 3D.

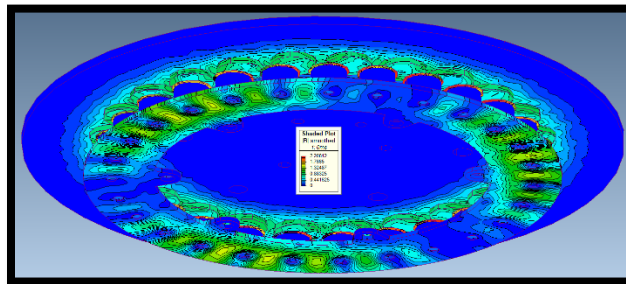

Figure 20: 2D Finite Element Analysis using FEMM.



DESIGN, DEVELOPMENT, AND MANUFACTURING OF BRUSHLESS
PERMANENT MAGNET MOTORS, MOTOR CONTROL AND MOTOR DRIVES

10.0 About Us

Power Electronics Group (PEG) designs, develops and manufactures brushless permanent magnet/BLDC motors and motor drives for customer-specific applications. PEG also comprehensively analyzes motors, motion control and drive products, and systems. PEG helps customers with optimal design selection, sizing, and configuration of Motion Control Systems.

PEG's staff has developed a critical understanding and has published on a wide range of permanent magnet/BLDC motors, motor control, motor drives, high-frequency electromagnetic components, electric vehicles, and switch-mode power systems. PEG's staff has co-authored over 30 publications in various refereed journals and conference proceedings and filed for several issued or pending US patents.

PEG has significant skills in motor engineering, mechanical engineering, power electronics, analog and digital electronics, software engineering, test engineering, manufacturing engineering, system simulation, design, and integration.

PEG has successfully delivered permanent magnet motors, motor drives, and battery management systems in electric vehicles, bicycles, scooters, power wheelchairs, and washing machines. PEG has an in-depth understanding of consumer, medical, automotive, and industrial systems requirements.

PEG's staff has extensively pursued technology beyond the traditional three-phase motors by designing seven- and five-phase radial as well as axial flux permanent magnet brushless motors.



DESIGN, DEVELOPMENT, AND MANUFACTURING OF BRUSHLESS
PERMANENT MAGNET MOTORS, MOTOR CONTROL AND MOTOR DRIVES



Figure 21: PEG's 5-Phase Falco Motor Technology Offers the lowest weight and highest power and torque density in today's light electric vehicle industry.

PEG is headquartered in the Shenandoah Valley and has significant research, development, and manufacturing capability in permanent magnet brushless motors, motor control, and motor drive systems. Currently, PEG has offices in the US and India. PEG's research, development, and manufacturing are in Pune, India.

PEG has developed a unique and highly successful approach called CARE™ to product development and project management for complex technology products involving embedded systems, electromagnetic and electro-mechanical components, and power electronics. Our CARE™ approach has four main elements –

- Clearly defined customer requirements
- Ample focus on analysis, simulation, and modeling
- Rapid prototyping
- Effective project management techniques

We bring products to fruition in a short time. We combine the best practical, technical and academic knowledge to deliver our clients unique competitive advantages.



DESIGN, DEVELOPMENT, AND MANUFACTURING OF BRUSHLESS
PERMANENT MAGNET MOTORS, MOTOR CONTROL AND MOTOR DRIVES

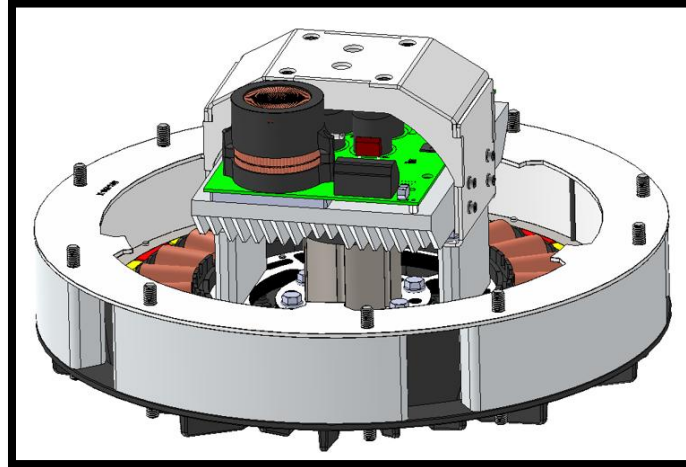

Figure 22: World's First 300Nm Fan HVLS (High Volume Low Speed) Platform launched in a record time.

Team at PEG

PEG has a talented and robust engineering team of

Motor engineers

specializing in the design of motors and high-frequency magnetic components using FEA (Finite Element Analysis) and analytical methods.

Electrical engineers

specializing in power electronics, analog, and digital circuit design.

Mechanical engineers

specializing in 3-D modeling and chassis design with diecast and CNC machined components using SolidWorks.

Software engineers

specializing in algorithm and programming for TI, ST, and Microchip DSPs and Micro-controllers.

Embedded engineers

specializing in digital circuit design, Network communication protocol implementation (CAN, RS232, RS485, I2C, MODBUS, SERCOS, Device Net, and Profibus), C and C++ programming.

Layout engineers

for designing printed circuit boards for harsh consumer, automotive, medical and industrial applications.



DESIGN, DEVELOPMENT, AND MANUFACTURING OF BRUSHLESS
PERMANENT MAGNET MOTORS, MOTOR CONTROL AND MOTOR DRIVES

Test engineers

for designing customer-specific test stands with National Instrument's LABVIEW™ Software.

Project engineers

to ensure performance, schedule and cost objectives.

Research & Simulation engineers

to further the understanding of PWM techniques, fuzzy logic, field-oriented, space vector and sensor less control methods.

Manufacturing engineers

specializing in shorter production time with minimum risk.

11.0 Our Vision

To bring remarkable value to our customers by helping them create cutting-edge technology products in Permanent Magnet Motors, Motor Control, and Motor Drives and Systems.

12.0 Our Mission

We are committed to acquiring and applying state-of-the-art knowledge, tools, methods, and processes to deliver the most exceptional value to our customers. We are committed to protecting our customers' interests with the highest level of integrity and ethics.

13.0 Our Core Values

Truth: Commitment to facts.

Promise: Commitment to promises made.

Honesty and Integrity: Commit to honesty and truth by promoting transparency.

Fairness and Justice: Commitment to fairness and justice inside and outside the company.

Excellence: Commitment to excellence to our customers.



DESIGN, DEVELOPMENT, AND MANUFACTURING OF BRUSHLESS
PERMANENT MAGNET MOTORS, MOTOR CONTROL AND MOTOR DRIVES

14.0 About Rakesh



Rakesh Dhawan founded the Power Electronics Group (formerly Strategic Technology Group) in 2009. He is a thirty-four-year veteran of the motors and motor drive Industry. Rakesh has developed a critical understanding and has published on a wide range of motors, motor drives, high-frequency electromagnetic components, electric vehicles, and switch-mode power systems. He has co-authored over 25 publications in various refereed journals and conference proceedings and is an inventor of eleven issued or pending US patents. Rakesh has served on the Technical Committee of the Applied Power Electronics Conference (APEC). He received a B. Tech (Electrical Engineering) degree from Indian Institute of Technology (IIT), Kharagpur, India. Rakesh received his MS degree from the University of Minnesota under the tutelage of Power Electronics pioneer Prof. Ned Mohan. He received his MBA from Old Dominion University.

He has been directly responsible for over twenty-five successful product launches in his career, many involving brushless permanent magnet motor systems. Rakesh has conducted several workshops in the field of motors and motor drives. His interests include brushless permanent magnet motor systems, light electric vehicles, electric bicycles, switch mode power supplies, solar inverters, simulation, statistics, project management, and new and ultra-fast product development methodologies. Rakesh is a high-energy individual with a difference; he combines technology excellence, leadership, and professional management skills with his inborn entrepreneurial instincts.

Rakesh is a senior member of IEEE is very keen on nurturing innovation and entrepreneurial talent in the field of technology development and management.



DESIGN, DEVELOPMENT, AND MANUFACTURING OF BRUSHLESS
PERMANENT MAGNET MOTORS, MOTOR CONTROL AND MOTOR DRIVES

16.0 Some of our customers



17.0 Registration Details

Early Bird Pricing (Until March 31, 2025):

- Industry Professionals: \$795
- Students: \$295
- Faculty: \$495

Regular Pricing (After March 31, 2025):

- Industry Professionals: \$1295
- Students: \$495
- Faculty: \$795



DESIGN, DEVELOPMENT, AND MANUFACTURING OF BRUSHLESS
PERMANENT MAGNET MOTORS, MOTOR CONTROL AND MOTOR DRIVES

How to Register

Visit: www.powerelectronicsgroup.com/workshops

Email: info@powerelectronicsgroup.com

Phone: +1 (571) 781-2453

Payments can be made via credit card, bank transfer, or PayPal. Seats will be confirmed upon payment.

18.0. Course Deliverables

- Course workbook (soft copy)
- Presentation slides, tools, and design methodologies
- Real-world case studies and project templates
- Certificate of Completion

19.0. Cancellation Policy

- Full refund (minus \$50 administration fee) for cancellations made **20+ business days before the event**.
- No refunds for cancellations **less than 20 days before the event**, but participants may transfer their registration to another attendee.

Contact Information

Power Electronics Group LLC
25 North Liberty St. Harrisonburg, VA 22802, USA

Phone: +1 (571) 781-2453

Website: www.powerelectronicsgroup.com

Email: info@powerelectronicsgroup.com

Copyright © 2025 - 2026 PEG. All rights reserved.